



THE HOME
OF GENUINE



PIT BOSS®
EQUIPMENT

Portable Rip Rap Plant

Heavy Duty Coarse Material Separator

The ELRUS Heavy Duty Rip Rap plant is a coarse material separator that is designed to remove fines, scalp oversize rock and sort remaining stone by size.

The plant features a 16 cubic yard hopper with hydraulic side dump grizzly, vibrating grizzly feeder, front discharge chute, cross conveyor feed hopper and side discharge chute, which enables the production of up to four products simultaneously.

Material Flow (Sizing Zones)

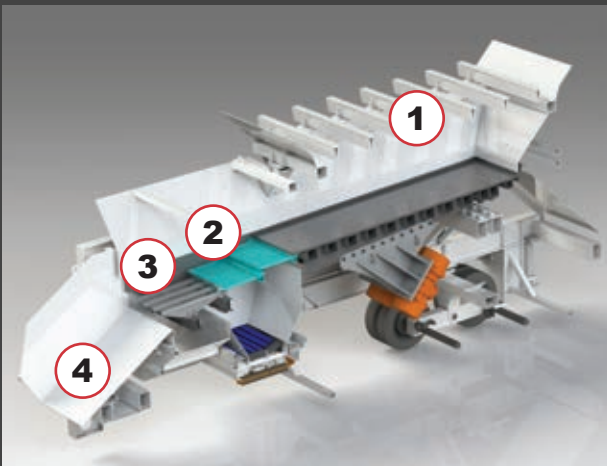

1. Hydraulic Side Dump Grizzly
 - Adjustable bars remove oversize material.
2. 4' Section of Adjustable Step Deck Fingers
 - (2 sizing zones) 3" Spacing
3. 4' section with 1 1/4" QT adjustable bars
4. 3/4" MS plate front discharge chute with flat bar stiffeners

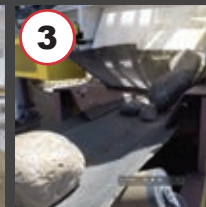
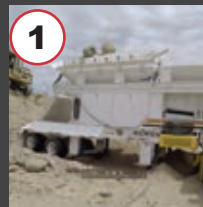

GENERAL SPECS



16 Cubic Yard Hopper

- 3/4" Plate construction with additional 3/4" plate leg support pads
- 8" WF horizontal support beams with 3 – 16" WF upright support per side
- Spill deflector on rear of skid



Hydraulic Side Dump Grizzly

- Extra heavy duty adjustable 10" tri bar grizzly bars
- 5 hinges w/ case hardened bushings and pins.
- 3' wing wall hopper extensions
- Fast cycle time



Vibrating Grizzly Feeder

54"x24' Vibrating Grizzly Feeder

- 4' section QT adjustable step deck fingers (2 sizing zones)
- 4' section QT adjustable bars
- Adjustable Throw - Adjust material flow

Two (2) 17.4 H.P. Vibrating Motors

- No bearings, sheaves, belts or guards - No parts to inventory
- Low Maintenance (No Oil No Belts)



Tandem Axle Walking Beam Suspension

- Increased strength & stability
- No springs to break
- Easy installation (4 bolts)



36" Side Discharge Conveyor w/ 4' Impact Bed

- 3/4" MS plate (8 - 12" material)
- 12" Rubber lagged head pulley
- 12" Self-cleaning tail pulley
- Full length skirting to contain material



Side Discharge Chute

- 3/4" MS plate (3-12" material)



Front Discharge Chute

- 3/4" MS plate with flat bar stiffeners



21" WF main frame skid

- 21" WF upright supports & 3/4" plate pads
- 8" WF Hopper sub-frame
- 12 Volt operation
- Fast set up

12V Hydraulic Leveling & Blocking Legs

- 12 Volt operation
- Six (6) blocking legs (two fold down)
- Enables fast set up and increased stability

General Dimensions & Weights

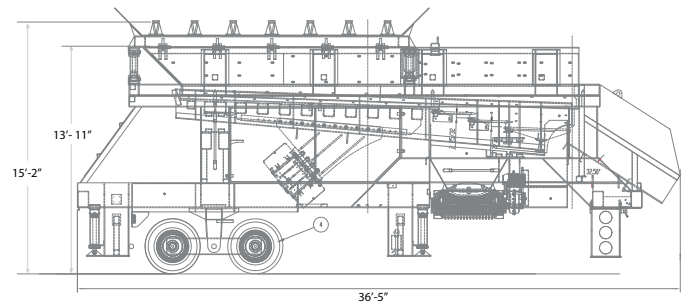

Travel Dimensions

- Width 13'-9"
- Height: 13'-11"
- Axle Weight: 18,700 kg (41,226 lbs)
- Pin Weight: 8,100 kg (17,851 lbs)



For more information visit: www.elrus.com or call 888-535-7877